

SPECIFICATION	CONNECTION	BIPOLAR
VOLTAGE (VDC)		12 TO 48
AMPS/PHASE		4.2 A
THREAD DIAMETER (mm) [in]		9.525 [0.375]
THREAD LEAD(mm) [in]		10.16 [0.4]
THRUST (N)		346
RESOLUTION (mm/STEP)		0.0508
MAX. SPEED (mm/sec.) AT 48V		254
WEIGHT (Kg) [lb]		0.95 [2.09]

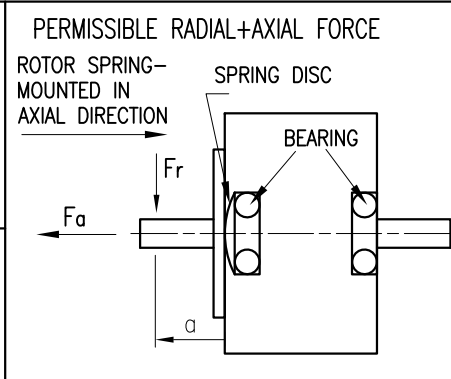
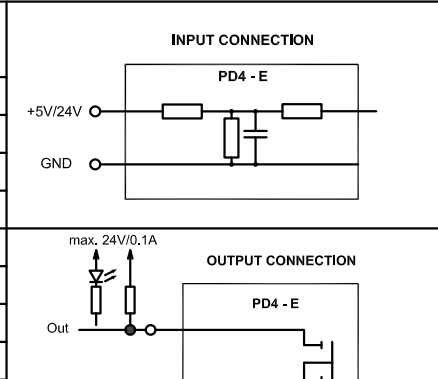

X1 EtherNET / IP IN (M12, 4-Pole, D-coding, female)	
Pin No.	Function
1	TD+
2	RD+
3	TD-
4	RD-

X3 Power (M12, 5-Pole, B-coding, male)	
Pin No.	Function
1	+UB (12-48V)
2	+UB (12-48V)
3	GND
4	GND
5	N.C.

X4 IO (M12, 12-Pole, A-coding, male)	
Pin No.	Function
1	GND
2	Input 1 (+5V/+24V)
3	Input 2 (+5V/+24V)
4	Input 3 (+5V/+24V)
5	Input 4 (+5V/+24V)
6	Input 5 (+5V/+24V)
7	Input 6 (+5V/+24V)
8	Analog Input (0-10V/0-20mA)
9	Output 1 (open drain)
10	Output 2 (open drain)
11	+5V Voltage Supply (max. 100mA)
12	+UB Logic (24V)

Please regard the application note at www.nanotec.com for further informations.

				 Nanotec [®] PLUG & DRIVE			APVD	<i>P.R.</i>	01.02.23	PLUG&DRIVE MOTOR	
							CHKD	<i>GYQ</i>	01.02.23		
				Surface specification DIN ISO 1302	General tolerances DIN ISO 2768- cH	Work piece edge DIN ISO 13715	DRN	<i>X T</i>	01.02.23	DWG.NO	
							SIGNATURE		DATE		PSA56S-E-3-VQKE-152
REV	DESCRIPTION	DATE	DRN								