

# Reference Sheet **ASA56**



# Contents

<b>1 Document, audience, intended use.....</b>	<b>3</b>
<b>2 Your product.....</b>	<b>3</b>
2.1 Highlights.....	3
2.2 ASA56 variants.....	3
2.3 Product layout.....	3
<b>3 Technical data.....</b>	<b>4</b>
3.1 Ambient conditions.....	4
3.2 Motor.....	4
3.3 Encoder.....	4
3.4 Pin assignment.....	5
<b>4 Sensor data format.....</b>	<b>5</b>
<b>5 Imprint, marking, versions.....</b>	<b>6</b>

## 1 Document, audience, intended use

Nanotec's ASA56 and this document address to technically trained experts alone, such as developers, application /plant engineers, fitters, and service staff. Only experts may install, commission and run the product. Always required is the qualification for the product's assembly, commissioning and maintenance as part of an **overall** machine /system, as well as:

- Training and experience in working with motors, their control and electrostatically threatened components
- Reading and understanding of this and all applicable documents
- Knowledge of all valid regulations

Place this PDF in valid version always to hand and accessible. Use ASA56 as intended only, within allowed technical limits and ambients. For product combinations, please contact Nanotec Sales.

### Disclaimer

Product modification /alteration is illicit. Nanotec is not liable for damage /malfunction from installation error, failure to observe this document, or undue repair; nor for product integration in the end system or interaction (= third-party ware). The audience alone is liable for selecting /running /using our products. Our risk analysis for partly completed machinery (if applicable) only rated the hazards of duly installed and networked *single* products. Risks in the *overall* system are exempt and to be rated by the *audience*. The general terms & conditions at [www.nanotec.com](http://www.nanotec.com) apply ([us.nanotec.com](http://us.nanotec.com) for clients of Nanotec USA).

## 2 Your product

ASA56 is a stepper motor in IP65 protection (save shaft outlet) with integrated incremental or multi-turn encoder for drive systems in a wide range of industrial scenarios.

### 2.1 Highlights

Typical ASA56 features are: size variance, holding force, and precision.

- UL certificate
- Protection class IP65 (shaft outlet: IP54)
- High encoder resolution
- 2 motor sizes
- Optional brake integrated (on request)

### 2.2 ASA56 variants

Find your product variant by its article number.

ASA5618~~X~~42-xxX      Motor length **Medium** | **Large**  
 ASA5618x42-~~xx~~X      Encoder **E3**: Incremental | **W1**: SSI

### 2.3 Product layout

Familiarize yourself with ASA56's product layout and technical data so as to avert added hazards (say, abrupt motor travel on defect / inhibition from your **overall** construct).

- ASA56 size sheet
- Torque tool to bolt the motor
- Flange *NEMA23*
- 4 *M5* screws 8.8 (ISO 4762 /10642)

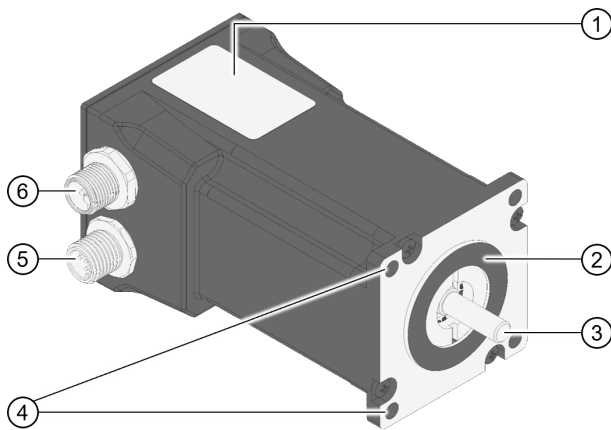

Fig. 1: ASA56 (here: size L).

1. Type label
2. IP54 ball bearing
3. Motor shaft
4. Four fixing bores *M5*
5. Encoder connector
6. Motor connector

### 3 Technical data

Keep the product within its technical limits. The size sheet on our website applies. Select the exact ASA56 type there and download the needed CAD-/ PDF file.

#### 3.1 Ambient conditions

Save for the shaft / leadscrew outlet (= *IP54*), the ASA56 is *IP65*-protected. For *overall IP65*, you must seal the outlet installation-wards, say, by O-ring or surface seal.

Protection class	IP65 (shaft outlet: IP54)
Air humidity (non-condensing)	0 to 85 %
Ambient °C (°F)	-10 to +50 °C (+14 to +122 °F)
Axial force $F_a$ N <sup>max.</sup>	10
Radial force $F_r$ (@ 10 mm) N <sup>max.</sup>	28

#### 3.2 Motor

There are two ASA56 lengths, each with a different holding torque.

ASA56 stepper	M size	L size
Current <sup>per winding</sup> A	4.2	4.2
Resistance <sup>per phase</sup> (@ 25 °C / 77 °F) $\Omega^{\pm 15\%}$	0.45	0.55
Inductance <sup>per phase</sup> (@ 1kHz) mH <sup><math>\pm 20\%</math></sup>	1.6	2.1
Rotor inertia kg·m <sup>2</sup> (x10 <sup>-6</sup> )	30	48
Holding torque Nm	1.4	2.3
Step angle <sup><math>\pm 5\%</math></sup>	1.8	1.8
Axial play ( $F_a = 4.0$ N) mm	0.08	0.08
Radial play ( $F_r = 4.0$ N) mm	0.02	0.02

#### 3.3 Encoder

ASA56 encoders work incremental or, in the SSI version, *multi-turn*.

	SSI	Incremental
Protective circuits	Reverse polarity, short circuit	Overvoltage
Energy harvesting	Wiegand effect	-/-
Operating voltage	4.75 to 15 VDC	5 VDC <sup><math>\pm 10\%</math></sup>
Consumption (typical)	$\leq 0.3$ W	$\leq 30$ mA (no-load @ 5 V)

	SSI	Incremental
Start-up time	100 ms	-/-
Clock input	RS 422	-/-
Sensor type	Magnetic	Magnetic
Incremental cpr / ppr <sup>squared</sup>	-/-	4096 / 16384
SSI ( <i>single-/multi-turn</i> ) bit	17 / 16	-/-
Accuracy	±0.0878° (@ room temperature)	±0.02° (@ standstill)
Axis rotation count <sup>seen from front</sup>	Clockwise	Clockwise
Maximum rpm	12,000	14,000

### 3.4 Pin assignment

**NOTICE**



**Electronic damage: from lack of reverse polarity protection!**

- ▶ Assign pins correctly.
- ▶ Use correct connector types.

#### Motor and encoder

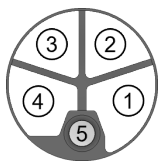

Fig. 2: Motor. L-coded M12 (m).

1: A\	3: B	5: n/a
2: A	4: B\	

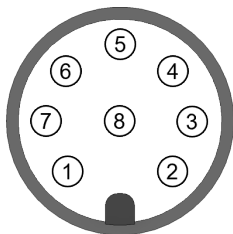

Fig. 3: Encoder. A-coded M12 (m).

<b>SSI:</b>	1: Clk+	3: Data+	5: Gnd	7: n/c
	2: Clk-	4: Data-	6: n/c	8: +Ub
<b>Incremental:</b>	1: A	3: B	5: Gnd	7: I
	2: A\	4: B\	6: I\	8: +Ub

### 4 Sensor data format

Depending on type, the ASA56's encoder sends the motor position incrementally via two channels **A**, **B** plus index **I** or via **synchron-seriell-interface** (SSI) as a 33-bit packet (after 16 start bits).

#### Incremental output

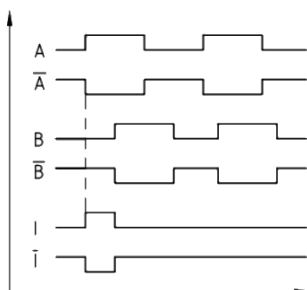

Fig. 4: The index signal **I** runs in sync with channel **A**'s rising edge.

If the motor shaft rotates clockwise (seen from front), channel **A**'s signal leads channel **B** by 90 degrees (electrical).

<b>Ub = 5 V</b>	<b>Load</b>	<b>High level</b>	<b>Low level</b>
A, A\, B, B\, I, I\	35 mA	≥ 4.5 V	≤ 0.3 V

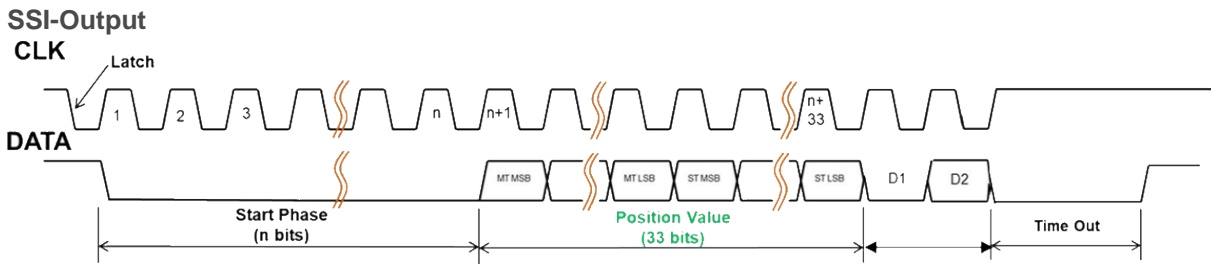

Fig. 5: By synchronous serial interface (SSI), the ASA56's encoder transfers the position values as 33-bit packets.

- **S303B**
- Cycle:  $\geq 50 \mu s$
- Time-out:  $7 \mu s^{typ.}$
- 16 Start bits (= 0) + multi-turn (16 bits) + single-turn (17 bits) + D1 + D2
- D1: Constant value = 0
- D2: Error-bit for displaying the sensor-internal status (1 = no error; 0 = error)

**Prepare the SSI for Nanotec controllers**

63	62	61	60	59	58	57	56	55	54	53	52	51	50	49	48
													0	0	0
47	46	45	44	43	42	41	40	39	38	37	36	35	34	33	32
0	0	0	0	0	0	0	0	0	0	0	0	0	POS	POS	POS
31	30	29	28	27	26	25	24	23	22	21	20	19	18	17	16
POS	POS	POS	POS	POS	POS	POS	POS	POS	POS	POS	POS	POS	POS	POS	POS
15	14	13	12	11	10	9	8	7	6	5	4	3	2	1	0
POS	POS	POS	POS	POS	POS	POS	POS	POS	POS	POS	POS	POS	POS	S	E

Fig. 6: ASA56 uses 51 status, start and position bits: 1 **S** for status (D1), 1 **E** for error (D2), 33 **POS** for position and 16 start bits (= 0).

- **Bit 0** (= error): value 1 if no error
- **Bit 1**: always value 0

Edit the 33B0<sub>n</sub> **sub-indices** below so that Nanotec controllers in *Autosetup* (see controller manual) duly process the encoder and its data:

1. Set 33B0<sub>n</sub>:06<sub>h</sub> to 2000000 (baud rate in Hz).
2. Set 33B0<sub>n</sub>:05<sub>h</sub> to 51 (number of bits plus start bits).
3. Set 33B0<sub>n</sub>:07<sub>h</sub> to FFFFFFFC<sub>h</sub> (Position data: POS bits 2 to 31).
4. Set 33B0<sub>n</sub>:08<sub>h</sub> to 7 (Position data: POS bits 32 to 34).
5. Set 33B0<sub>n</sub>:09<sub>h</sub> to 3 (status and error bits 0 and 1).
6. Set 33B0<sub>n</sub>:0B<sub>h</sub> to 1 (error bit = 1, status bit = 0).
7. To store the object: Insert 65766173<sub>h</sub> to 1010<sub>n</sub>:06<sub>h</sub>.
8. Restart the controller.

**5 Imprint, marking, versions**

© 2024 Nanotec Electronic GmbH & Co. KG | Kapellenstr. 6 | 85622 Feldkirchen | Germany | Tel. +49 89 900 686-0 | Fax +49 89 900 686-50 | info@nanotec.de | www.nanotec.com | All rights reserved. Error, omission or change possible without notice. Quoted brands/products are trademarks of their owners and to be treated as such. Observed for conformity was: *RoHS Directive 2015/863/EU* (others on request).

**Document + Added | > Changed | # Fixed**

- 1.0.1<sup>2024.11</sup> + Revision.
- 1.0.0<sup>2023.11</sup> Release.

