

Reference Sheet **ASA86**

For the following variants:

E3 (= incremental), W1 (= SSI)

Contents

1 Document, audience, intended use.....	3
2 Your product.....	3
2.1 Highlights.....	3
2.2 ASA86 variants.....	3
2.3 Product layout.....	3
3 Technical data.....	4
3.1 Ambient conditions.....	4
3.2 Motor.....	4
3.3 Encoder.....	4
3.4 Pin assignment.....	5
4 Sensor data format.....	5
5 Imprint, marking, versions.....	6

1 Document, audience, intended use

Nanotec's ASA86 and this document address to technically trained experts alone, such as developers, application /plant engineers, installers, and service staff. Only experts may install, commission and run the product. Always required is the qualification for the product's assembly, commissioning and maintenance as part of an **overall** machine /system, as well as:

- Training and experience in working with motors, their control and electrostatically threatened components
- Reading and understanding of this and all applicable documents
- Knowledge of all valid regulations

Use the product as intended only, within allowed technical limits and ambients. For product combinations, please contact Nanotec Sales.

Disclaimer

Product modification /alteration is illicit. Nanotec is not liable for damage /malfunction from installation error, failure to observe this document, or undue repair; nor for product integration in the end system, or interaction with undue third-party goods. The audience alone is liable for selecting /running /using our products. Our risk analysis for partly completed machinery (if applicable) only rated the hazards of duly installed and networked *single* products. Risks in the *overall* system are exempt and to be rated by the *audience*. The general terms & conditions at www.nanotec.com apply (us.nanotec.com for clients of Nanotec USA).

2 Your product

ASA86 is a stepper motor in IP65 protection (save shaft outlet) with integrated incremental or multi-turn encoder for drive systems in a wide range of industrial scenarios.

2.1 Highlights

Typical ASA86 features are: size variance, holding force, and precision.

- 2 motor sizes
- Protection class IP65 (shaft outlet: IP54)
- High encoder resolution
- Optional brake integrated (on request)

2.2 ASA86 variants

Find your product variant by its article number.

ASA8618 ^x 9504-xxX	Motor length Medium Large
ASA8618x9504- xxX	Encoder E3 : Incremental W1 : SSI
ASA8618x9504-xx B	With Brake (letter omitted otherwise)

2.3 Product layout

For product installation, please use the size sheet (CAD-/ PDF download) from our website's ASA86 menu. Before first use, *do* fit the product true to standard, by the allowed fixing points, interfaces and tools. Avert added hazards, such as abrupt motor travel on defect / inhibition in the **overall** construct, or heat build-up from poor sink. You now need:

- ASA86 size sheet
- U-flange Ø 70 mm (9-mm steel; 12-mm Al)
- Torque tool
- ISO 4762 /10642 screws 8.8:
4 M6 (10.1 / 7.9 Nm) to bolt the motor

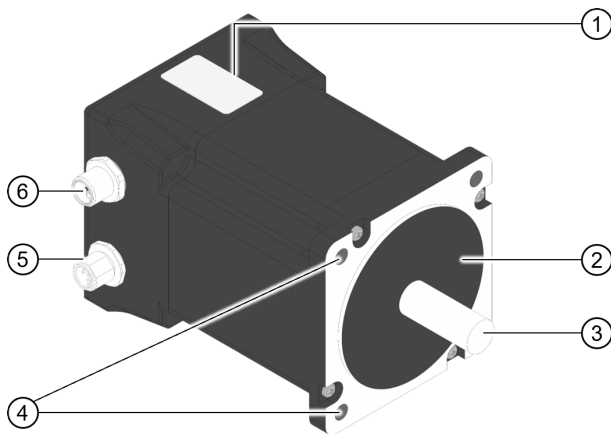

Fig. 1: ASA86 (here: size M).

1. Type label
2. IP54 shim ring
3. Motor shaft
4. Four fixing bores M6
5. Encoder connector
6. Motor connector

3 Technical data

Keep the product within its technical limits. The size sheet on our website applies. Select the exact ASA86 type there and download the needed CAD-/ PDF file.

3.1 Ambient conditions

Save for the shaft outlet (= IP54), the ASA86 is IP65-protected. For overall IP65, you must seal the shim ring installation-sided, say, by O-ring or surface seal.

Protection class	IP65 (shaft outlet: IP54)
Air humidity (non-condensing)	0 to 85 %
Ambient °C (°F)	-10 to +50 °C (+14 to +122 °F)
Axial force F_a N ^{max.}	≤ 10
Radial force F_r (@ 5 mm) N ^{max.}	≤ 28

3.2 Motor

There are two ASA86 lengths with different rated power.

ASA86 stepper	M size	L size
Current ^{per winding} A	9.5	9.5
Resistance ^{per phase} (@ 25 °C / 77 °F) $\Omega^{\pm 15\%}$	0.23	0.26
Inductance ^{per phase} (@ 1kHz) mH ^{±20%}	2.3	2.4
Holding torque Nm	5.9	9.3
Step angle ^{±5%}	1.8	1.8
Axial play ($F_a = 4.0$ N) mm	0.08	0.08
Radial play ($F_r = 4.0$ N) mm	0.02	0.02

3.3 Encoder

NOTICE



Electronic damage: from disregard of ESD-sensitive product parts!

► Observe basic principles of ESD protection.

ASA86 encoders give incremental 4096 cpr or, in the SSI version, 17 bit (*single-*) and 16 bit (*multi-turn*).

	SSI	Incremental
Protective circuits	Reverse polarity, short circuit	Overvoltage
Energy harvesting	Wiegand effect	-/-
Operating voltage	4.75 to 15 VDC	5 VDC \pm 10%
Consumption (typical)	\leq 0.3 W	\leq 30 mA (no-load @ 5 V)
Start-up time	100 ms	-/-
Clock input	RS 422	-/-
Sensor type	Magnetic	Magnetic
Incremental cpr/ppr ^{squared}	-/-	4096 / 16384
SSI (<i>single-/multi-turn</i>) bit	17 / 16	-/-
Accuracy	\pm 0.0878° (@ room temperature)	\pm 0.02° (@ standstill)
Axis rotation count ^{seen from front}	Clockwise	Clockwise
Maximum rpm	12,000	14,000

3.4 Pin assignment

NOTICE



Electronic damage: from wrong supply polarity!

- ▶ Assign pins correctly.
- ▶ Use correct connector types.

Motor and encoder

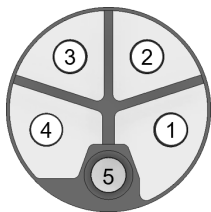

Fig. 2: Motor (= L-coded M12 male).

1: A\ 2: A 3: B 4: B\ 5: n/a

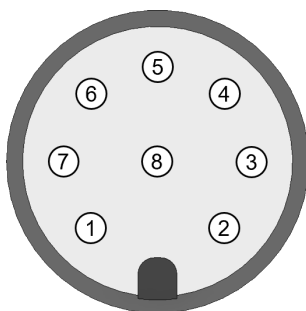

Fig. 3: Encoder (= A-coded M12male).

SSI:	1: Clk+	3: Data+	5: Gnd	7: -/-
	2: Clk-	4: Data-	6: -/-	8: +Ub
Incremental:	1: A	3: B	5: Gnd	7: I
	2: A\	4: B\	6: I\	8: +Ub

4 Sensor data format

Depending on type, the ASA86's encoder sends the motor position incrementally via two channels **A**, **B** plus index **I** or via **synchron-seriell-interface (SSI)** as a 33-bit packet (after 16 start bits).

Incremental output

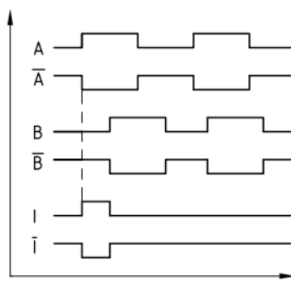

Fig. 4: The index signal I runs in sync with channel A's rising edge.

If the motor shaft rotates clockwise (seen from front), channel A's signal leads channel B by 90 degrees (electrical).

Ub = 5 V	Load	High level	Low level
A, A̅, B, B̅, I, I̅	35 mA	≥ 4.5 V	≤ 0.3 V

SSI-Output

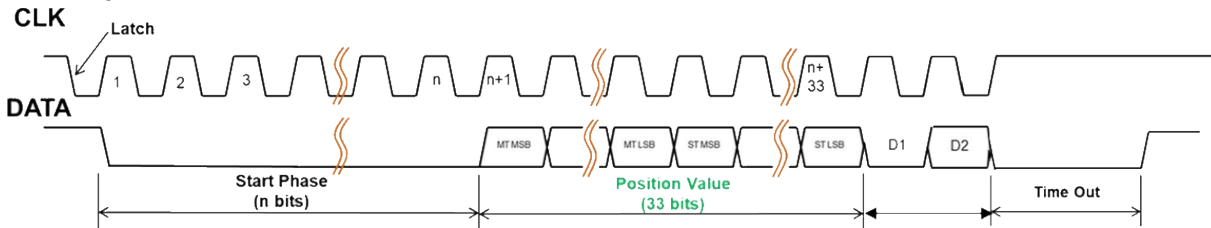

Fig. 5: By synchronous serial interface (SSI), the ASA86's encoder transfers the position values as 33-bit packets.

- **S303B**
- Cycle: ≥ 50 μs
- Time-out: 7 μs^{typ.}
- 16 Start bits (= 0) + multi-turn (16 bits) + single-turn (17 bits) + D1 + D2
- D1: Constant value = 0
- D2: Error-bit for displaying the sensor-internal status (1 = no error; 0 = error)

Prepare the SSI for Nanotec CPB controllers

63	62	61	60	59	58	57	56	55	54	53	52	51	50	49	48
													0	0	0
47	46	45	44	43	42	41	40	39	38	37	36	35	34	33	32
0	0	0	0	0	0	0	0	0	0	0	0	0	POS	POS	POS
31	30	29	28	27	26	25	24	23	22	21	20	19	18	17	16
POS	POS	POS	POS	POS	POS	POS	POS	POS	POS	POS	POS	POS	POS	POS	POS
15	14	13	12	11	10	9	8	7	6	5	4	3	2	1	0
POS	POS	POS	POS	POS	POS	POS	POS	POS	POS	POS	POS	POS	POS	S	E

Fig. 6: ASA86 uses 51 status, start and position bits: 1 S for status (D1), 1 E for error (D2), 33 POS for position and 16 start bits (= 0).

- **Bit 0** (= error): value 1 if no error
- **Bit 1**: always value 0

Edit the 33B0_n **sub-indices** below so that Nanotec CPB controllers in *Autosetup* (see controller manual) du-ly process the encoder and its data:

1. Set 33B0_n:06_h to 2000000 (baud rate in Hz).
2. Set 33B0_n:05_h to 51 (number of bits plus start bits).
3. Set 33B0_n:07_h to FFFFFFFC_h (Position data: POS bits 2 to 31).
4. Set 33B0_n:08_h to 7 (Position data: POS bits 32 to 34).
5. Set 33B0_n:09_h to 3 (status and error bits 0 and 1).
6. Set 33B0_n:0B_h to 1 (error bit = 1, status bit = 0).
7. To store the object: Insert 65766173_h to 1010_n:06_h.
8. Restart the controller.

5 Imprint, marking, versions

© 2024 Nanotec Electronic GmbH & Co. KG | Kapellenstr. 6 | 85622 Feldkirchen | Germany | Tel. +49 89 900 686-0 | Fax +49 89 900 686-50 | info@nanotec.de | www.nanotec.com | All rights reserved. Error, omission or change possible without notice. Quoted brands /products are trademarks of their owners and to be treated as such. Observed for conformity was: RoHS Directive 2015/863/EU (others on request).

Document **+ Added** | **> Changed** | **# Fixed**
1.0.0^{2024.05} Release.

